

CAEM 222  
March 15, 2017

### Museum Storage Mounts for Burden Baskets

Burden baskets are part of the basketry tradition of many communities throughout the western United States and California. Despite regional and cultural differences in materials used, design and decoration, all burden baskets are designed to be held upright – either with straps or a carrying net – the position in which they are most stable.



Illustration 1: Left: Burden basket with carrying net from the Dry Creek Rancheria, image courtesy of <http://drycreekrancheria.com/photo-gallery-of-dry-creek-pomo-baskets/>, Right: Coast Pomo woman with a burden basket, c. 1924. Image courtesy of the Art Institute of Chicago, [http://www.artic.edu/aic/collections/artwork/49918?search\\_no=1&index=4](http://www.artic.edu/aic/collections/artwork/49918?search_no=1&index=4)

Because of their conical shape, these baskets can only either lay on their sides or stand upside-down on the rim when they are not in use, both of which put strain on the structure. Museums will usually store burden baskets upside-down in an effort to keep the pressure on the rim even, however even in this position gravity can put great strain on the rim – which was not designed to be weight-bearing. This can cause warping and distortion of the overall basket shape, and if weaknesses or cracks exist, the added stress can cause them to propagate further into the basket, traveling along the lines of the warps and severing the wefts.

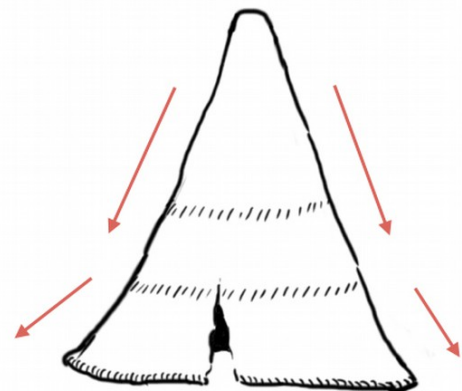

Illustration 2: The stress of gravity on a burden basket on its rim. Any existing breaks are pushed open by the weight. Diagram by the author.

## How mounts can help

Storage mounts can help by holding the burden basket upright in the position in which it was designed to be held, therefore taking the strain off the rim and help mitigate existing damage and prevent new damage. Such mounts are easy to make with materials which are readily available as well as archival and suitable for long-term storage.

**Tools and materials** (all materials here are listed from [www.talasonline.com](http://www.talasonline.com), a bookbinder and conservation supplier)

### Materials

- Archival corrugated blue board sheets (ie. [http://www.talasonline.com/Heritage-Corrugated?custcol\\_matrix\\_type=64](http://www.talasonline.com/Heritage-Corrugated?custcol_matrix_type=64))
- 2" Ethafoam (*closed cell polyethylene*) sheet (ie. <http://www.talasonline.com/Ethafoam-Planks>)
- ¼" Volara (*a smooth polyethylene*) sheet (ie. <http://www.talasonline.com/Volara-Foam>)
- Low temperature, archival grade hot glue (ie. <http://www.talasonline.com/Thermogrip-6363-Hot-Melt-Glue>)
- 1" Tyvek (*spun-bonded 100% high density polyethylene olefin fabric*) tape (ie. [http://www.talasonline.com/Tyvek-Tape?custcol\\_matrix\\_size\\_vol=88](http://www.talasonline.com/Tyvek-Tape?custcol_matrix_size_vol=88))
- 3M™ 415 Polyester Double-Sided Tape (ie. <http://www.gaylord.com/Preservation/Conservation-Supplies/Tape/3M%26%23153%3B-415-Polyester-Double-Sided-Tape-%2836-yds-%29/p/HYB00644>)

### Tools

Scissors  
 Box cutter  
 Low temperature glue gun  
 Bulldog or binder clips  
 Cutting mat  
 Large work-surface

## Step by step

### 1. Making the tray:

Using the diameter of the burden basket as a guide, make a tray with a lip of about 1 inch out of the corrugated blue board by scoring the board with a box cutter one inch from the edge on all sides. At the corners, cut one of each of the scored lines to make a foldable tab (*see illustration 3*).

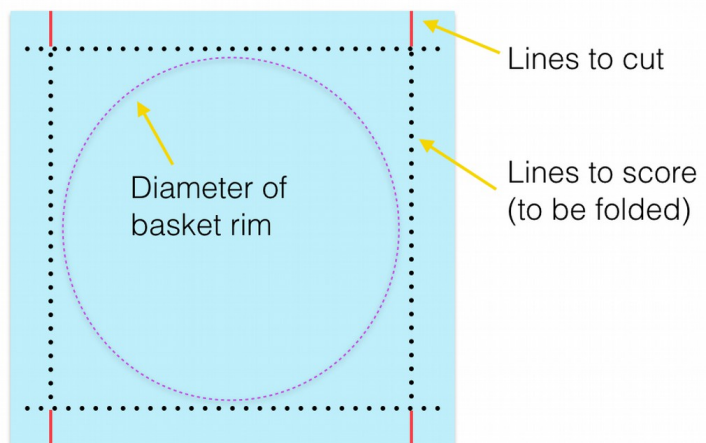

Illustration 3: How to score and cut blue board for a bottom tray.

Bend all of the scored lines, creating a tray with all four walls folded upwards. Also make sure to bend each of the foldable tabs around its corner.

Glue the folded corner tabs of the tray with hot glue and clamp in place with bulldog clips, or something just as strong, until the glue has cooled and can hold the corners on its own.

Place a small patch of ¼” Volara foam in the middle to pad the tray at the spot where the burden basket’s conical base will touch. Adhere this piece of foam down with double-sided tape (don’t use the hot glue, as it will melt the Volara, causing it to collapse and loose its softness)

## 2. Making the supports:

Using a box-cutter, cut three triangles out of the thick, 2” Ethafoam. These will be the supports which actually hold the basket in place. You can custom fit them by holding them up to the basket and trimming with the box-cutter until the fit is good. A profile gauge can be used to aid this process by taking the profile of the side of the basket and using that to pattern the custom fit of the supports.

Arrange these supports like a tripod in the middle of the tray and (with a second, helping set of hands) fit the basket in place, taking care to make sure it is centered and not overhanging the sides of the tray – in this way, if the basket is placed on a shelf and pushed, the tray will bump anything that might be in the way (ie. the back wall) before the rim of the basket does.

Adhere the triangle supports in place with hot glue, then cut rectangles of Volara to pad the sides of the triangles which will touch the basket. Again, adhere the Volara with double-sided tape.

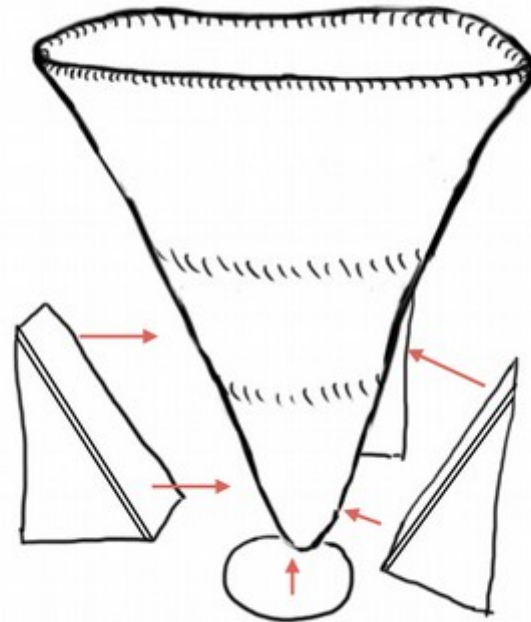

*Illustration 4: How to place the triangular supports (made of Ethafoam with a top layer of protective Volara) against a burden basket, as well as the round Volara pad to be placed below the base of the basket. Image by author.*

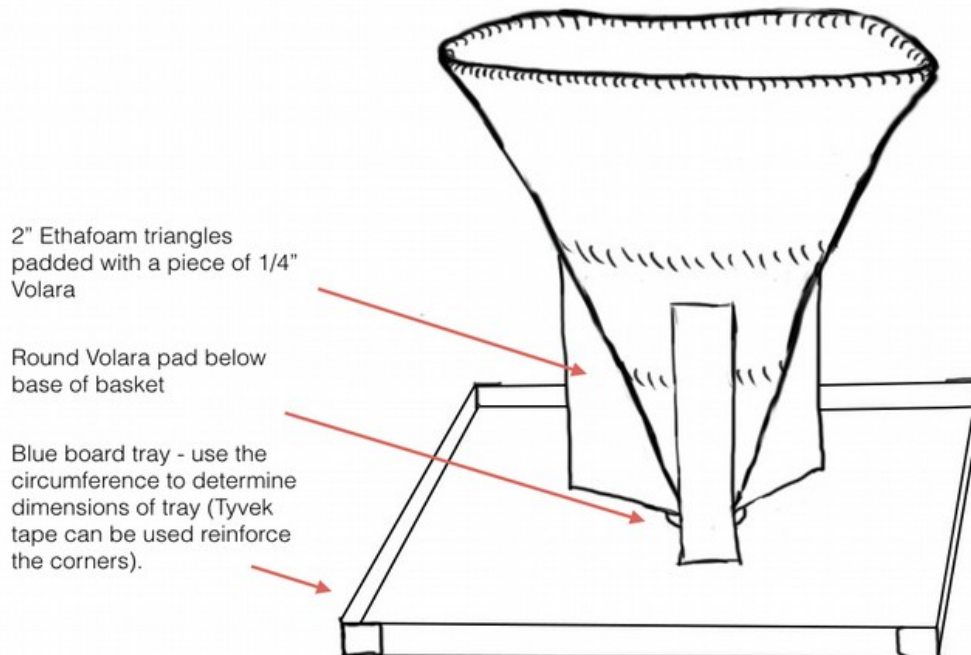

Illustration 5: diagram of a completed mount.

Once in their mounts, burden baskets can be returned to storage. The strain has now been taken off the basket rims and the baskets will be more stable over the long term. Because the tray should be of nearly the same circumference as the rim, little extra space should be taken up by the mounts.

## Resources

Aboe, G. "Packaging and Storage Solutions for Archaeological Basketry: a Selection of Practical Designs". *Journal of the Institute of Conservation*, Vol. 35, No. 1 (2012), pp. 103-111.

Beisel, C., Hommenick, K., Swierenga, H., & Toutloff, M. A Guide to Foam and Black Tray Mounts, accessed on March 1, 2017 at: [http://moa.ubc.ca/wp-content/uploads/2014/09/Resources\\_Conservation-black\\_tray\\_manual.pdf](http://moa.ubc.ca/wp-content/uploads/2014/09/Resources_Conservation-black_tray_manual.pdf)

Clark, T. "Storage Supports for a Basket Collection: A Preventive Conservation Approach". *Journal of the American Institute for Conservation*, Vol. 27, No. 2 (Autumn, 1988), pp. 87-99.